

Screw Tip Assembly Quote Request Form

To request a quote, simply call 800-627-1033 with the following information:

CUSTOMERNAME: _____ CONTACT: _____

CUSTOMERNO.: _____ PHONENO.: _____ FAX NO.: _____

SPECIFICATIONS

1. Machine Make & Size _____

2. Construction Material: H-13 Heat Treated and Nitrided Steel CPM-M4
 D-2 Heat Treated Steel CPM-420V
 CPM-9V

3. Dimensions (to 0.001"):

- A. Tip Overall Length _____
 B. Critical Forward Length _____
 C. Thread End to Seat Face _____
 D. Tip Threads _____
 E. Pilot O.D. _____
 F. Tip O.D. _____
 G. Tip Nose Angle _____
 H. # of Flutes _____
 I. Ring Width _____
 J. Ring O.D. _____
 K. Seat Width _____
 L. Seat O.D. _____

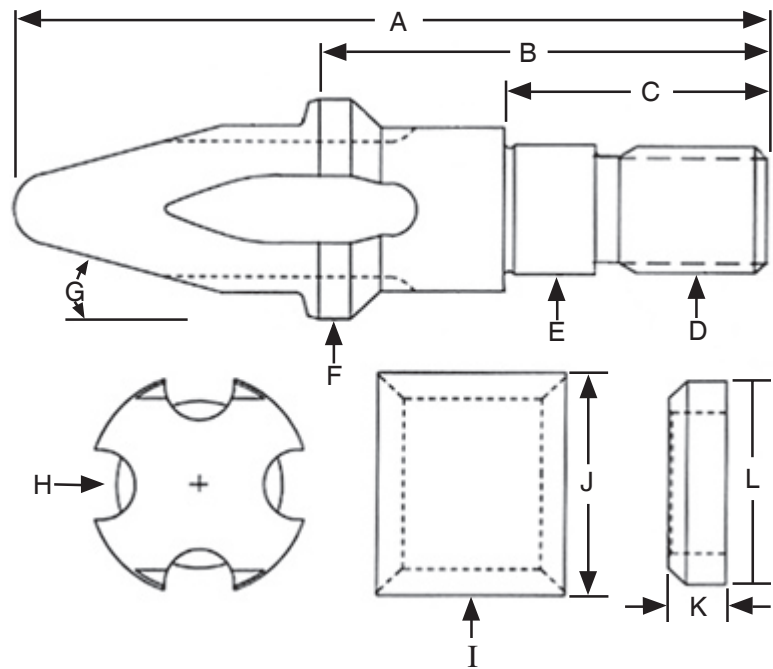

- 4 Design: Ball Check Valve Poppet Valve Smear Tip Sliding Ring Valve
 Rotating
 Non-rotating

5. Number of Pieces: 3-Piece Design 4-Piece Design

6. What material is being processed? _____

7. Additional Information _____